

introducing the new innovative fence system

DELTAVIEW 100

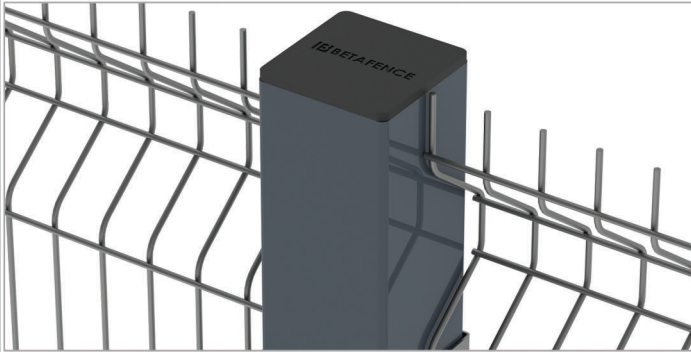

new - new - new - new - new - new - new - new - new - new

Betafence has developed the market's first eco-friendly perimeter fence that offers cost-effective security without compromising on quality or rigidity.



Affordable

DeltaView provides a cost-effective fence system without compromising on quality, security or ease of installation.



Durable

Despite its affordability, DeltaView is a rigid and robust fence system that offers effective security for a wide variety of applications.



Sustainable

Every step in the manufacturing process of the DeltaView system has been carefully engineered to create an eco-friendly product.

Up to 20% more cost-effective than comparative fence systems due to thinner wires and larger apertures. High tensile wire results in 30% increased penetration resistance against traditional hand tools. 10 Year Betafence Guarantee on complete DeltaView systems. DeltaView 100 clamps require no drilling during installation.

30% increased penetration resistance against hand tools by incorporating high-tensile wire. Tensile strength of wire: 800-900 MPa, weld strength at 75% of wire tensile strength. Flexibility tracks the same pattern as alternative fences for 260kg point loads. Posts and fixing mechanisms maintains the complete installation's integrity. Reinforced by means of 2 or more V-bends in the horizontal direction of the panel. Minimal visual impact, even at an angle - ideal for use with surveillance systems.

Up to 30% lighter than the average fence panel, reducing logistics costs and emissions which in turn improves air quality. The environmentally-friendly thermoplastic coating used on DeltaView is free of lead, cadmium and di-2-ethylhexylphthalate (DEHP). Production results in an average 30% reduction in carbon footprint. Manufactured from a high percentage of recycled material. Manufactured in South Africa.

Security Level



Applications



Functionalities



Panels

The panels are made from 2.7mm (3.0mm when coated) diameter horizontal and vertical core wire.

Available in 3m wide panels and three standard height options. Other heights available on request.

Larger Aperture

Deltaview 100 features a larger aperture (25x100mm when compared to our standard Betaview 25 System (76.2x25 mm)).

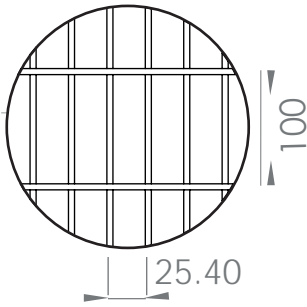

Durable High-Quality Coatings

Available as galvanized with thermoplastic coating in anthracite RAL 7021 or green RAL 6005.

MTO High Corrosive Environment Betafence's highly durable thermoplastic coatings and Zincalu® Super guarantee an extra-long lifespan and low maintenance, delivering superior protection in even the harshest environments.

Posts & Fixing Mechanisms



Square posts are designed and to be used in combination with Betafence's panels. With the Square Posts, the fence is mounted between the post. The panels are secured to the post with our Steel Clamp, firmly bolted using M6 stainless steel security bolts and shear-off nuts



This combination of Betafence panels with Square post and Precision Steel Clamp delivers a complete fencing system that ensures the installation's integrity and protection levels.

Optional features

Increase your perimeter's protection by adding top rails to further discourage climbing attempts.

Additional Security Accessories

Extended posts and brackets are available to accommodate additional security features such as electric fencing*, flat wrap razor, or BTC coil toppings.

*Supplied and installed by third parties.

Gates

For comprehensive access control solutions that ensure a uniform level of security throughout your perimeter, inquire about our fit-for-purpose range of swing and sliding gates.

Quality Assurance

Our range of high-security products are locally manufactured in our South African ISO 9001:2015 quality certified facility.

DELTAVIEW 100

Nominal fence height (mm)	Nominal panel width (mm)	Number of reinforcing V bends / panel	Post height (mm)	Number of Clamps/ post	Bolts, washers and shear-off nuts / post
1800	3050	3	2400	6	6
2100	3050	4	2700	8	8
2400	3050	4	3000	8	8

SOUTH AFRICA - WESTERN CAPE
Unit B10,
Bergriver Business Park,
Paarl, 7646, South Africa

TEL: +27 21 868 7300
info@betafence.co.za

SOUTH AFRICA - GAUTENG
Unit 3,
CDE Premium Park,
Johannesburg, 1685, South Africa

TEL: +27 11 314 8034
info@betafence.co.za

Betafence is the world market leader in fencing solutions, access control and detection for perimeter protection. All Betafence companies and product names are trademarks owned by PRÆSIDIAD Group Limited. Modification in products and assortment are subject to change without prior notice.

Proud to be a PRÆSIDIAD brand, Betafence is part of a global network, working alongside Guardiar and Hesco as a leader in perimeter security systems and solutions. For more information please visit praesidiad.com.



BETAFENCE
Securing What Matters
betafence.com/contact